



# **TOWN OF ROCKY HILL** **SIDEWALK SPECIFICATIONS**

Issued: January 1, 2014

## **GENERAL:**

All work and materials shall be in conformance with the State of Connecticut, Department of Transportation, Standard Specifications for Roads, Bridges and Incidental Construction, Form 816, 2004 as amended and these Specifications and Drawings. If a discrepancy occurs between Form 816 and these specifications, the Town specifications will govern. Materials must be from a **State Certified Vendor**.

All work and materials must be inspected by the Director Public Works or his agent. Any changes to these specifications must be approved by the Director Public Works or his agent.

Sidewalk Construction within the Town of Rocky Hill Right of Way requires a Street Excavation permit from the Town of Rocky Hill and work within the State Highway Right of Ways requires a DOT Encroachment Permit from the State of Connecticut Department of Transportation. Both permits require a permit fee, bond and insurance with forms available from the appropriate agency. The Town of Rocky Hill inspects sidewalk construction in both the town and state right of ways. A **24 hour notice** is required to arrange for an inspection.

The contractor is responsible for notifying Call Before You Dig (1-800-922-4455) prior to any on-site or off-site excavation.

## **MATERIAL:**

### **Base:**

Base material for this work shall be 3/4 inch processed aggregate conforming to DOT Form 816 material specification M.05. and must be from a **State Certified Vendor**.

### **Forms:**

Five (5") inch forms are to be made of standard steel construction or if necessary 2" x 6" wood, straight, free from warp and of sufficient strength to resist springing from the pressure of the concrete.

Eight (8") inch sidewalks forms are to full depth 8" steel forms or if necessary 2" x 8" wood, straight, free from warp and of sufficient strength to resist springing from the pressure of the concrete.

Sidewalk radii may be formed with plywood if properly supported and pinned.

**2" X 4" WOOD FORMS ARE NOT PERMITTED.**

### **Reinforcing Steel**

Reinforcing Steel shall be 6" x 6" No. 8 gage welded wire fabric conforming to DOT Form 816 material specification M.06.

Concrete:

Concrete for this work shall be five to seven percent (5-7%) air-entrained Class "C" or Class "F" Concrete with minimum compression strength of 4000 psi. conforming to DOT Form 816 material specification M.03. and must be from a **State Certified Vendor.**

Dowel:

Dowels shall be 5/8 inch smooth round dowels, 24 inches long. Both ends of said dowels shall be wrapped in aluminum foil or approved equal to prevent concrete from adhering to the bar.

Expansion Joint:

Expansion joint material shall be 1/2 inch thick and be full depth of the sidewalk thickness (5" or 8"). The joint material shall be asphaltic made for that purpose.

Curing Covers

Acceptable covers are cotton curing mats, waterproof paper or liquid membrane - forming curing compound.

Concrete Sealer

Concrete sealer shall be Consolideck® Saltguard® WB or approved equal.

Detectable Warning Strip

The detectable warning strip shall be a prefabricated warning surface tile as manufactured by Engineered Plastics Inc., Williamsville, NY, or approved equal. The tile shall have dimensions of 24" by 48" and have a **brick red** homogeneous color throughout or approved equal.

**CONSTRUCTION METHODS: ALL CONCRETE SIDEWALK**

Construction methods in this section shall be applicable to All Concrete Sidewalks in the Town of Rocky Hill. For construction specific to 5" Sidewalk, 8" Reinforced Sidewalk and Handicap Ramp see sections listed below.

Base

Base must be excavated to 17" below finished grade of the walk. It shall be placed meeting Town Specifications in two separate lifts of 6" and compacted thoroughly by suitable machinery. Base depth must be 12" for 5" sidewalk.

Forms

**2" X 4" WOOD FORMS ARE NOT PERMITTED.**

Forms shall be securely staked, braced and held firm to the line and grade and shall be tight to prevent leakage.

All forms shall be cleaned and oiled each time they are used for a pour.

The cross slope for a 4' walk is 1" slope toward gutter or as directed by the Director of Public Works or his agent to meet existing conditions.

Concrete

Prior to the placement of concrete in the forms, the subgrade shall be thoroughly dampened so that it is moist throughout, but without puddles of water.

Concrete shall be placed at a slump of no greater than 3 inches and shall only be placed when

suitable temperatures prevail.

No water is to be added to the mix without the Director of Public Works or his agent's approval.

#### Expansion Joints

Expansion joints must be placed every 15' from the beginning and end of every pour and where the 5" deep concrete meets the 8" deep concrete. Expansion joint material must be 1/2" x 5". Two 5/8" x 24" long smooth steel bars are to be used at every expansion joints.

Expansion joints are to be placed in forms before concrete is poured. Joints must not be pushed through wet cement. The steel bars are to be foil covered at both ends through expansion joint. This whole assembly is to be placed in forms before pour.

When connecting to existing concrete sidewalks a pair of holes 3/4 inch in diameter 12 inches deep shall be drilled into the existing concrete sidewalks and dowels and expansion joints shall be placed.

#### Finishing

When the concrete has been placed in the forms, struck off to grade and allowed to partially set (when all the water and water sheen has left the surface), said time not to exceed one (1) hour, the surface of the concrete shall be finished with a wood float or by other approved means.

After floating, the surface shall be floated with a steel trowel until a smooth even surface is obtained, and then it shall be broomed to a satisfactory finish with a fine bristle broom. Care shall be taken not to bring an excess of sand or water to the surface by over brooming.

Tooled joints (depth: 1-1/2" for 5", 2" for 8") shall be formed every five (5) feet with a jointing tool. A jointer shall be used to form a rounded edge not exceeding 1/4 inch radius at all surface edges.

#### Curing Compound

If curing compound is used, it should be applied as follows: As soon as the concrete has hardened enough so that the surface will not be marred, curing of concrete shall be accomplished using white pigmented curing compound conforming to "Specification for Liquid Membrane - forming compounds for Curing Concrete" (ASTM Designation: C-309). The curing compound shall be applied by hand operated or power driven spray equipment immediately after the concrete has been given its final finish. The concrete surface shall be moist when the coating is applied, apply two smooth and even textured coats to ensure complete coverage. The second coat shall be applied at right angles to the first. Such compounds shall be applied in accordance with the manufacture's recommendations.

#### Sealing Concrete

All concrete is to be sealed with Consolideck® Saltguard® WB or approved equal and applied per manufactures specifications.

#### Backfilling and Removal of Surplus Material

The sides of the sidewalk shall be backfilled with suitable material and rough graded after forms are removed to prevent trip hazard. All surplus material shall be removed and the site left in a neat and presentable condition to the satisfaction of the Director of Engineer or his agent. Loam, fine grading and seeding should take place when weather permits and as soon as possible. Spring - April 1st to June 15th Fall - August 15 to October 15th

Protection of the Work

Lighted barricades should be placed around new walks and all excavations at end of day's work. Any work destroyed by weather or by vandals will not be accepted and Contractor will be responsible for replacement.

**CONSTRUCTION METHODS: 5" CONCRETE SIDEWALK**

Construction methods shall be the same as for All Concrete Sidewalk with the following modifications:

Base

Base depth must be 12" for 5" sidewalk.

**CONSTRUCTION METHODS - 8" CONCRETE SIDEWALK:**

Construction methods shall be the same as for All Inch Concrete Sidewalk with the following modifications:

Base

Base depth must be 9" for 8" sidewalk and compacted in two separate lifts of 6" or less.

Forms:

Forms must remain in place for 48 hours for commercial drives or high early strength concrete may be used if next day access is desired.

Reinforcing Steel:

6" x 6" No. 8 gage welded wire fabric shall be installed. (As shown on detail sheet)

Protection of the Work:

At driveways to be opened to traffic the following day, high early strength concrete shall be used. At commercial driveways, one lane of access shall be open to traffic at all times. The Contractor is responsible to coordinate work with adjacent property owners the day before work is to commence.

**CONSTRUCTION METHODS – HANDICAP RAMP w/DETECTABLE WARNING STRIP:**

Construction Methods shall be the same as for 8" Inch Cement Concrete Sidewalk and installed as per the detail sheet.

The Detectable Warning Strip shall be set directly in the poured concrete ramp according to the plans and the manufacturer's specifications or as directed by the Director of Public Works.

The void left between the existing BCLC curbing and the new ramp shall be filled with bituminous concrete lip curbing. The void left between the existing granite curbing and the new ramp shall be filled with concrete. This work shall be in accordance with Town standards.

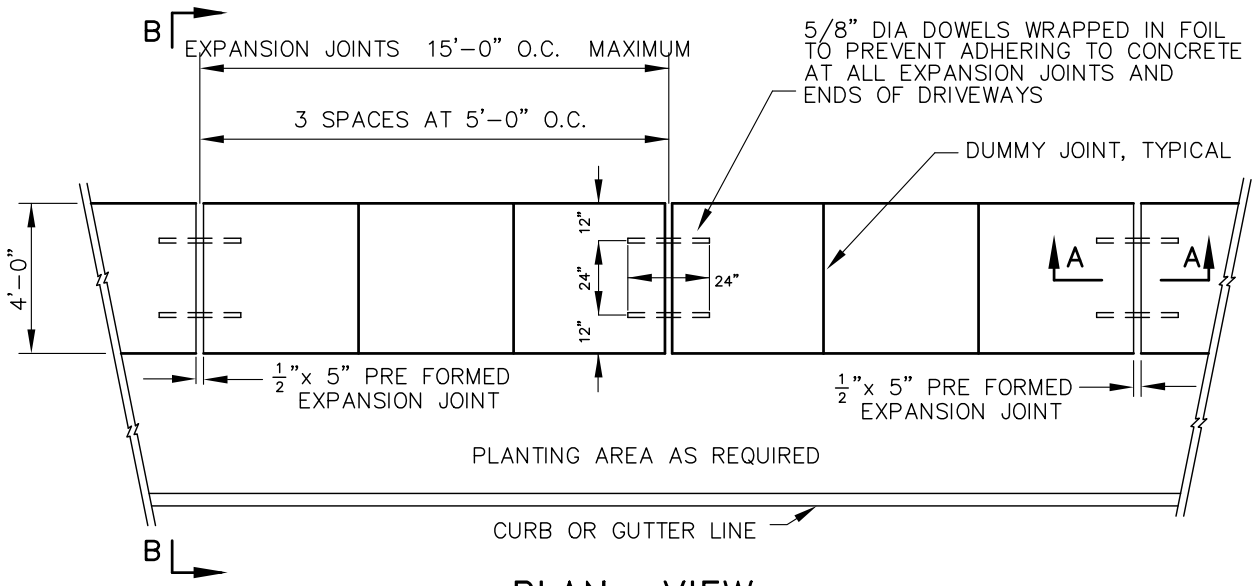

**PLAN VIEW**

ALL CONCRETE IS TO BE SEALED WITH CONSOLIDECK SALTGUARD WB OR APPROVED EQUAL

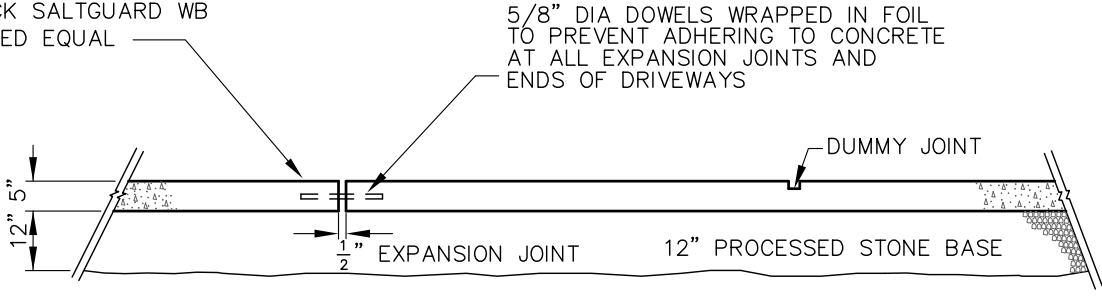

**SECTION A-A**

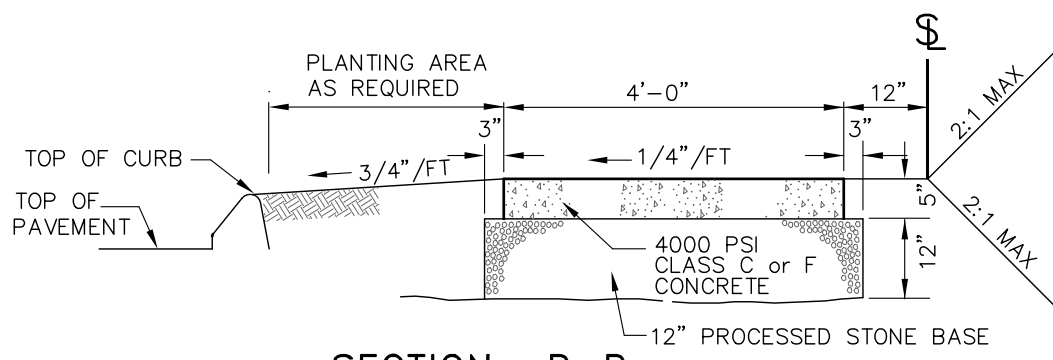

**SECTION B-B**

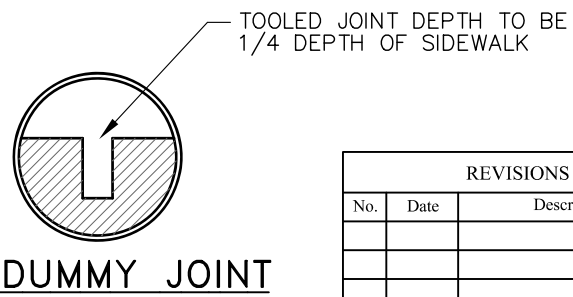



REVISIONS		
No.	Date	Description

**TOWN OF ROCKY HILL**  
**ENGINEERING DEPARTMENT**  
 761 OLD MAIN STREET, ROCKY HILL, CT 06067  
 PHONE (860)258-2766 FAX (860) 258-2703  
 James C. Sollmi P.E., L.S., Director of Engineering and Highways

**STANDARD DETAILS**

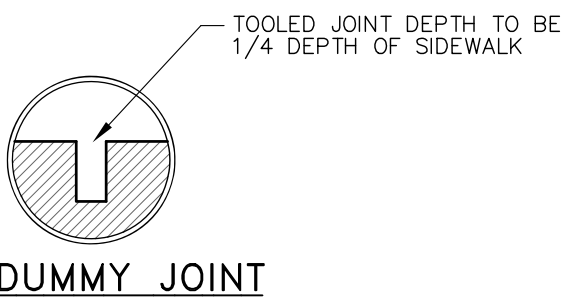
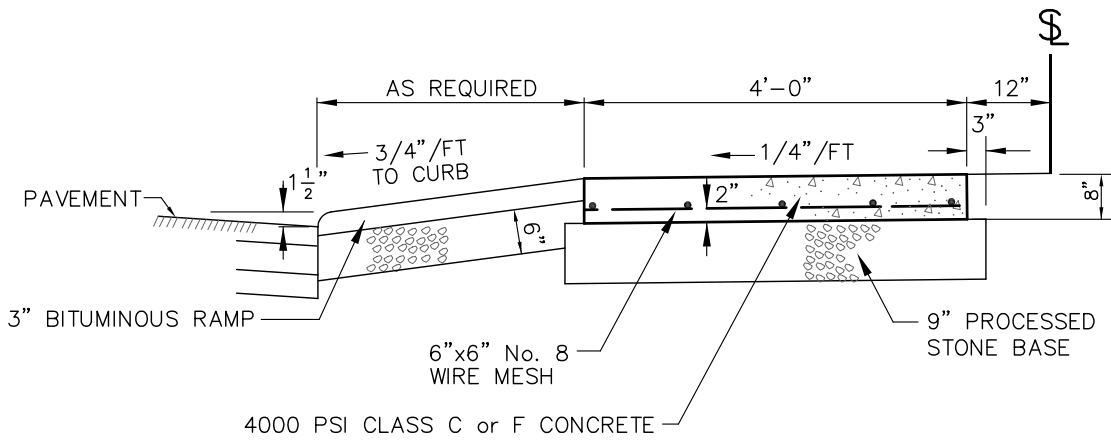
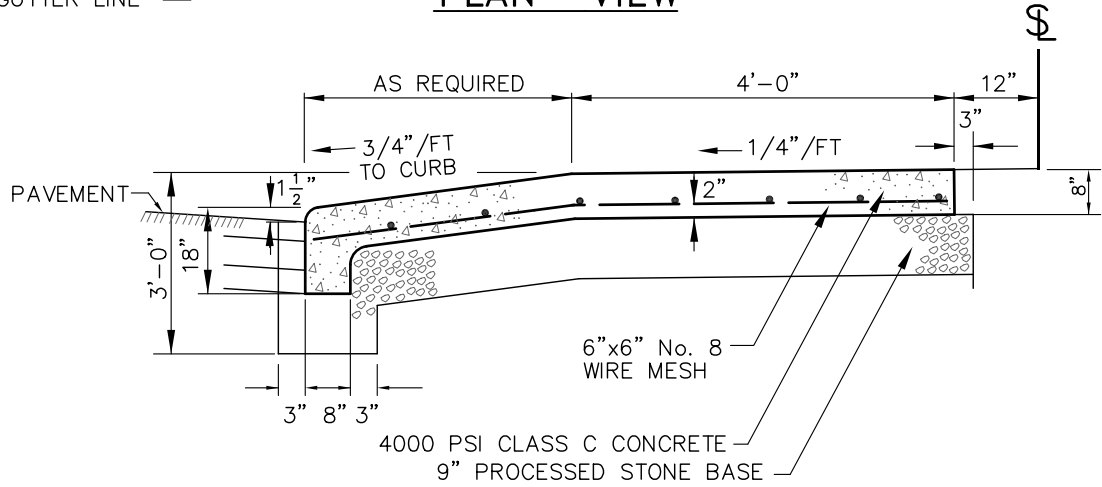
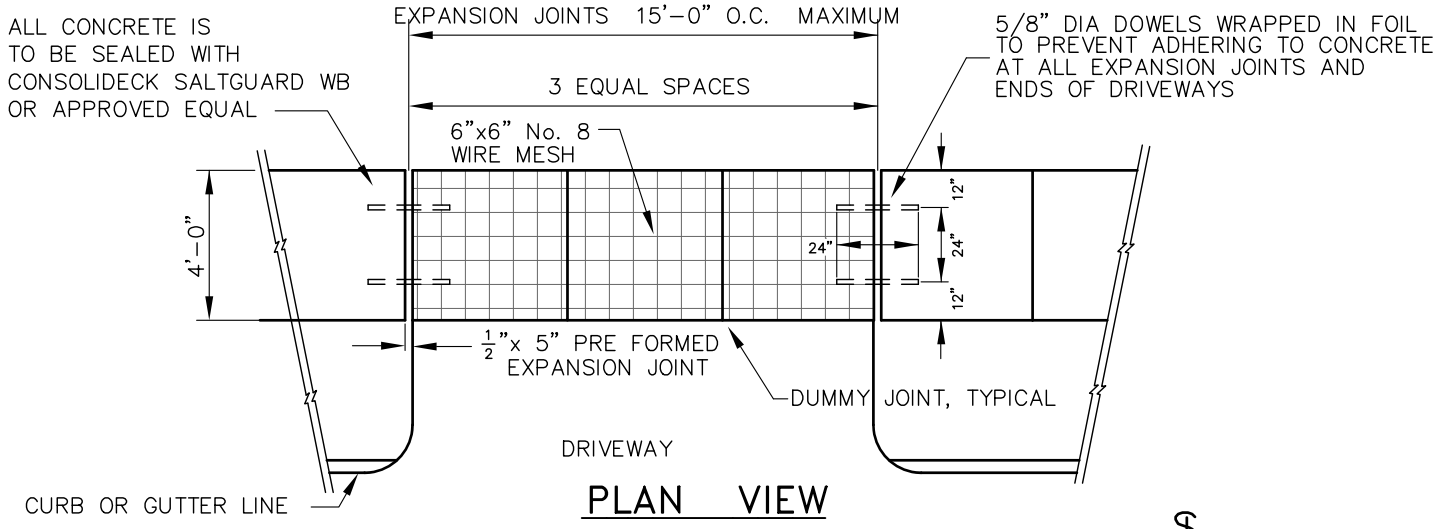
**5" CONCRETE SIDEWALK**



	<b>TOWN OF ROCKY HILL</b> <b>ENGINEERING DEPARTMENT</b> 761 OLD MAIN STREET, ROCKY HILL, CT 06067 PHONE (860)258-2766 FAX (860) 258-2703 James C. Sollmi P.E., L.S., Director of Engineering and Highways		
	<b>STANDARD DETAILS</b>		
<b>8" REINFORCED CONCRETE SIDEWALK</b>			
Date: 1/1/14	Scale: N.T.S.	Drawn By: SDS	Sheet: of